

Using *intelligent touch Manager*

1. A Daikin-trained engineer must perform installation of the *intelligent touch Manager*.
2. The clock of the *intelligent touch Manager* should be adjusted once a month.
3. Daikin's unique PPD system calculates the energy consumption of each indoor unit based on its operation data output. Note that PPD is not a "meter" adapted to the methods of measuring electrical power consumption in each country. Tenant billing systems differ by country according to each country's respective legal system. Data obtained by PPD is for reference use only and should not be used for official financial transactions.



JMI-0107

Organization:  
DAIKIN INDUSTRIES, LTD.  
AIR CONDITIONING MANUFACTURING DIVISION

Scope of Registration:  
THE DESIGN/DEVELOPMENT AND MANUFACTURE OF  
COMMERCIAL AIR CONDITIONING, HEATING, COOLING,  
REFRIGERATING EQUIPMENT, HEATING EQUIPMENT,  
RESIDENTIAL AIR CONDITIONING EQUIPMENT, HEAT  
RECLAIM VENTILATION, AIR CLEANING EQUIPMENT,  
COMPRESSORS AND VALVES.



EC99J2044

All of the Daikin Group's business  
facilities and subsidiaries in Japan  
are certified under the ISO 14001  
international standard for  
environment management.

Đại lý phân phối:



**DAIKIN INDUSTRIES, LTD.**

- Head Office  
Umeda Center Bldg., 2-4-12, Nakazaki-Nishi, Kita-ku, Osaka, 530-8323 Japan

- CÔNG TY CỔ PHẦN VIỆT KIM  
• VĂN PHÒNG CHÍNH  
Tầng 14-15, tòa nhà Nam Á, 201-203 Cách Mạng Tháng 8, P.4, Q.3, TP.HCM  
Tel: (08) 62 504 888 Fax: (08) 62 504 999
- CHI NHÁNH HÀ NỘI  
Tầng 12, tòa nhà Ocean Park Tower, 1 Đào Duy Anh, Quận Đống Đa, Hà Nội  
Tel: (04) 35 657 677 Fax: (04) 35 657 688
- CHI NHÁNH ĐÀ NẴNG  
Tầng 12, Lô A2.1, Đường 30/4, P. Hòa Cường Bắc, Q. Hải Châu, TP. Đà Nẵng  
Tel: (0511) 362 4250 Fax: (0511) 362 4251  
[www.daikin.com.vn](http://www.daikin.com.vn)

• Specifications, designs and other content appearing in this brochure are current as of May 2014 but subject to change without notice.



PCNG01214A

One touch selection to total air comfort



**ALL IN ONE** System solution for management of building air conditioning

**intelligent touch Manager**

# For Energy Saving & Comfort

## intelligent touch Manager maximises the advantages of VRV features

intelligent touch Manager is an advanced multi-zone controller that provides the most cost-effective way to control and monitor the Daikin VRV system.

The 10.4" LCD touch screen is easy to use with three different screen views to include the floor plan layout view, icon view and list view and menus for system configurations.

It is also easy to use with standardized remote Web Access from your PC.

It can manage a total of 650 management points consisting of up to 512 Daikin indoor unit groups ( up to 1024 indoor units ) along with building equipment control / monitoring with Digital Inputs / Output ( Di/Dio ) , Analog Inputs / Output ( Ai/Ao ) and Pulse input ( Pi ) optional devices.

### The new V1.20 software meets all of your control requirements such as

- BACnet connection with a wide range of building equipment.
- WAGO Ao and Pi are newly supported and connectable WAGO modules are added.

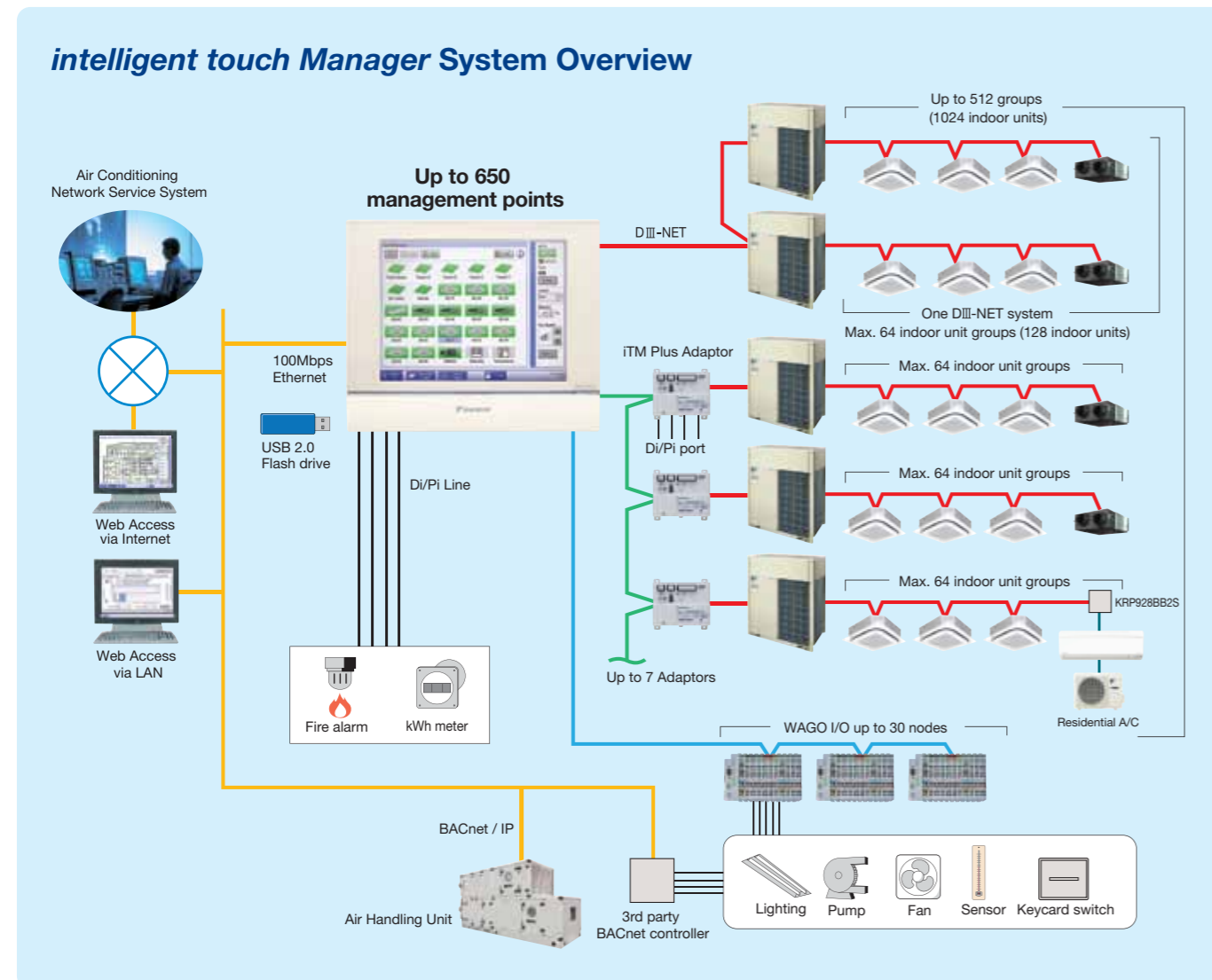

# Intuitive Monitoring & Control

## Anybody can easily manage VRV system

The easy - to - understand icon and intuitive menu will enable users to be an expert in managing the VRV system

**List view**

Designed for simplicity, this menu provides a quick view of overall status and essential information in a list format. Using the sorting function, VRV system operating under the same conditions and status are identified for comparison and assessment.

**Icon view**

**Area / Unit Detailed Settings**

ON

Filter sign

OFF

Error

**Layout view (Engineering option)**

A special feature utilises building floor plans to provide a visual representation of VRV system. Users can visually locate VRV indoor units on the floor plan.

Icon menus for configurations

**Easy Engineering**

The system configuration can be done through preset tool off-site then imported to the intelligent touch Manager via the USB port at the site. This feature makes engineering easier and more manageable.

Automatic control

System settings

Operation management

USB memory

# Only When and Where Necessary

## Schedule function for flexible management of time and setpoint

### Saving energy by preventing wasteful operation in unoccupied periods

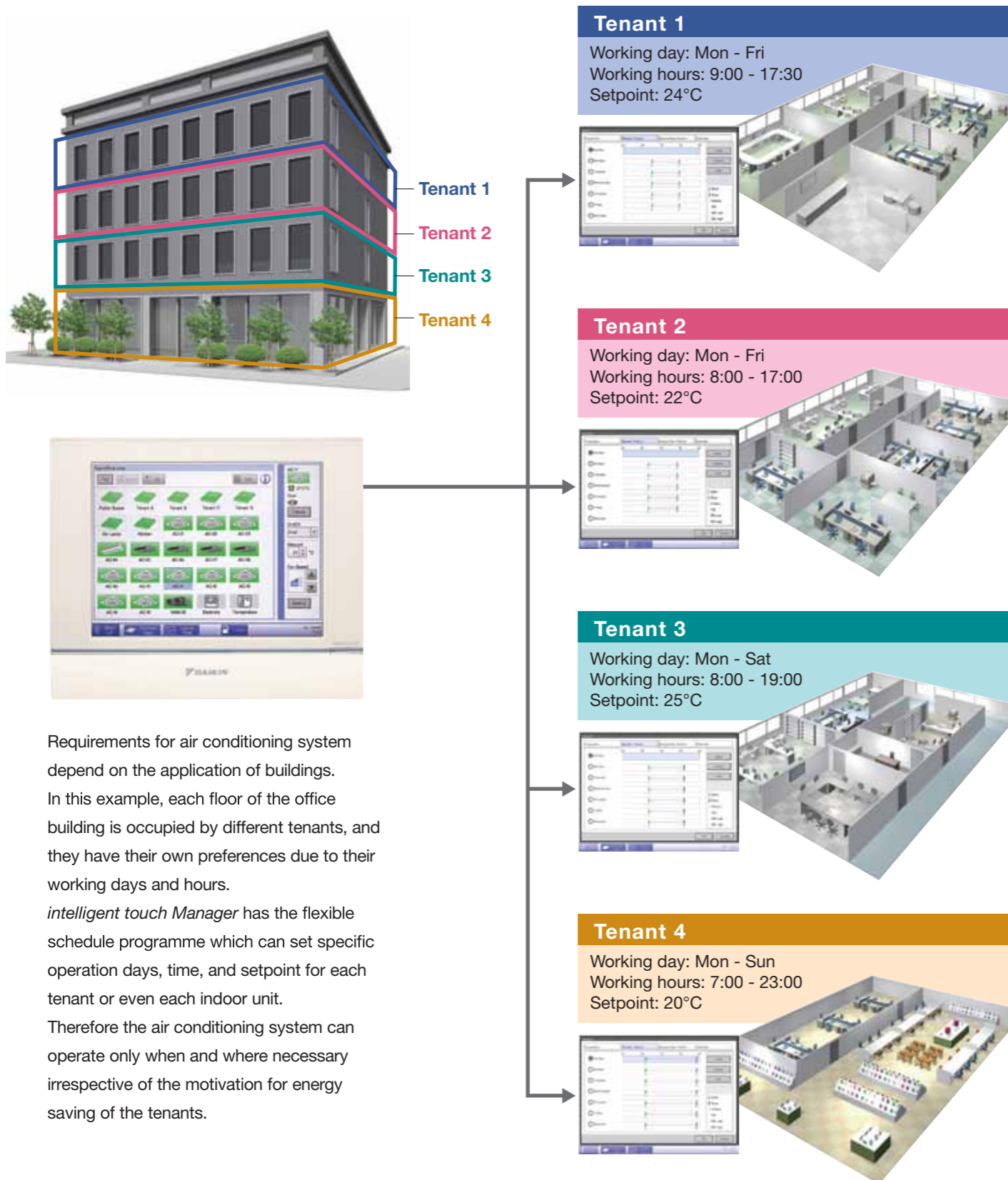

# Not Only VRF System, but Also Other Building Equipment

## Integrated control of various air conditioning-related equipment

### A wide variety of equipment can be connected

*intelligent touch Manager* covers not only the VRF system but also other air conditioning systems (e.g. air handling units) and building equipment (e.g. sensors).

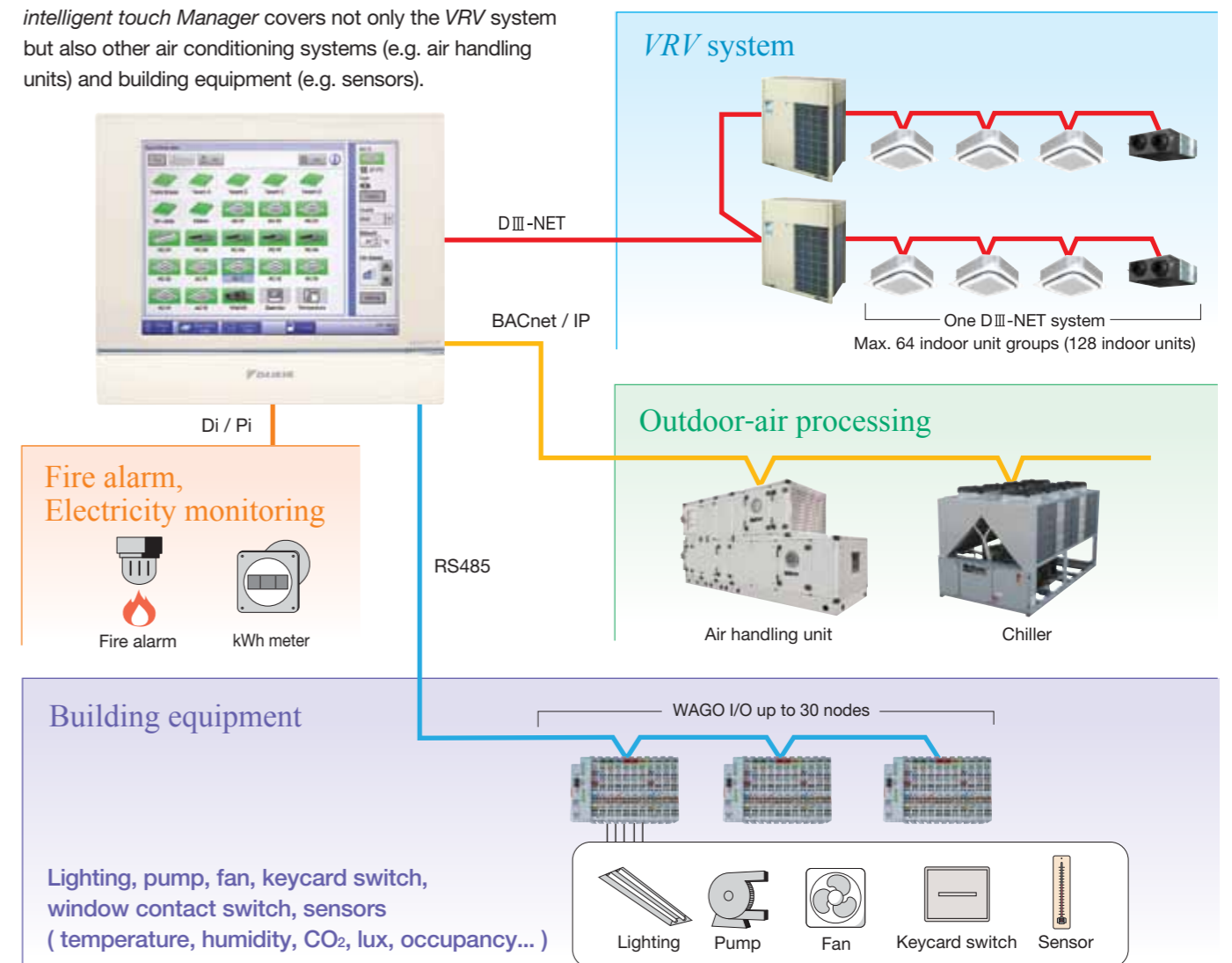

### Emergency stop for localised fire protection areas

By interlocking fire alarms, the system can perform an emergency stop of air conditioning and ventilation units and execute for either all air conditioning units or only affected fire protection areas.

Having centralised control to perform an emergency stop on localised fire protection areas offers building managers of multi-tenant buildings a choice for maximising safety of affected areas without disrupting activities of those areas that are unaffected.

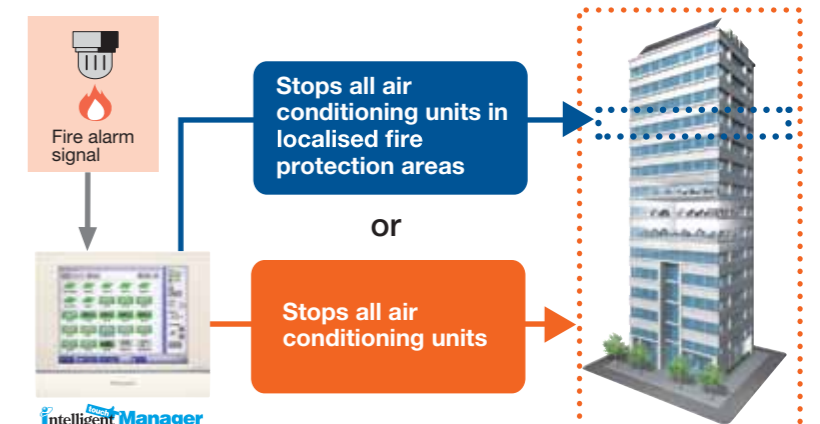

## Multiple buildings can be managed from one site

### Remote monitoring control

The Web function enables management for the Daikin VRV system with other building equipment integrated into *intelligent touch Manager* that can be accessed from your PC\*.

All operations and system configurations which you can do on the *intelligent touch Manager* touch screen can be done through Web access.

- Up to 4 administrators and 60 general users can be registered.
- Screens and operations accessible to general users can be restricted.

E-mail alert enables prompt response by service engineers based timely and precise knowledge of what happened in the system at the remote site.

- Up to 10 e-mail addresses can be set.
- SMTP server authentication method is selectable from no authentication, POP before SMTP, or SMTP-AUTH.

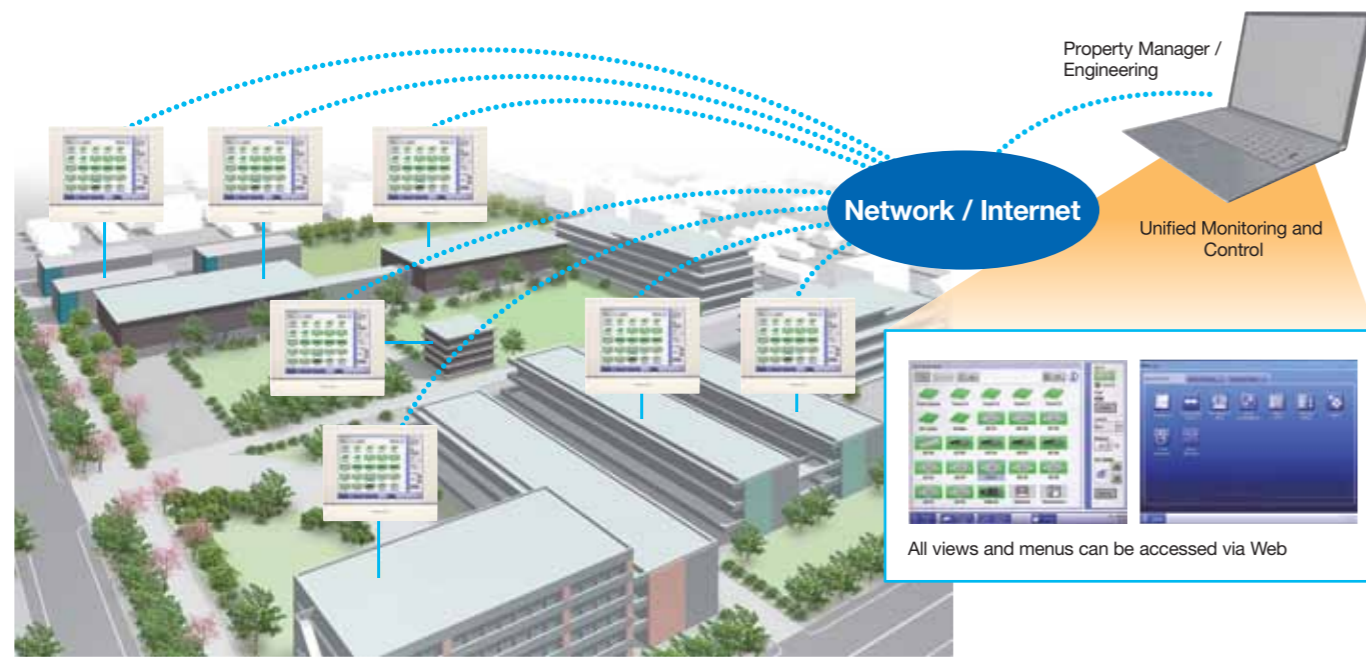

\*Flash player is required.

### E-mail alerts for reporting malfunctions

E-mail alerts are sent immediately to inform concerned parties of malfunctions involving equipment connected to the *intelligent touch Manager*. Conveying equipment models and error codes, these e-mail alerts enable recipients to take prompt action and can be set for specific equipment.



## Motivating for further energy saving

### Energy saving assisted by Energy Navigator (Option)

Energy consumption trends of all the equipment (including air conditioning units) can be easily understood by using the Energy Navigator feature. Here users can identify air conditioning units that are suspected of overcooling or kept running in unoccupied rooms. The Energy Navigator feature will also provide support in formulation and verification of energy-saving measures to help ensure advanced energy management.

Hourly energy consumption is measured and the *intelligent touch Manager* records data sent from the electrical meter.

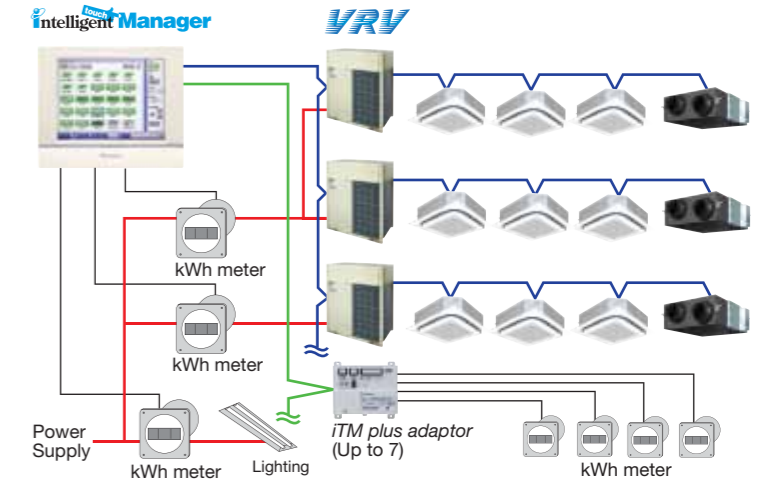

Accumulated data appears in an easy-to-understand graph.

Energy consumption data is presented on a daily and monthly basis. Also, energy targets and projected energy consumption data as well as comparison data with the previous year's actual results are presented in a user-friendly format to help ensure energy-saving control.

#### Daily energy consumption

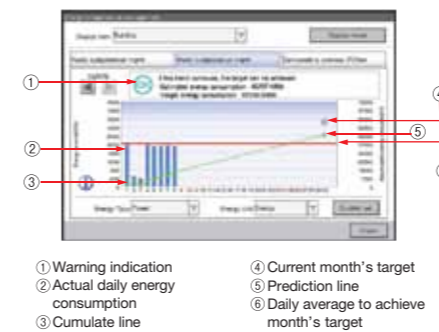

#### Monthly energy consumption

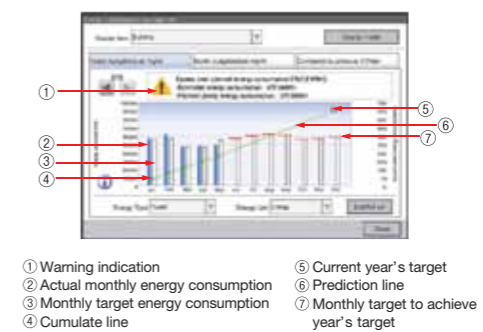

#### Comparison from the previous year

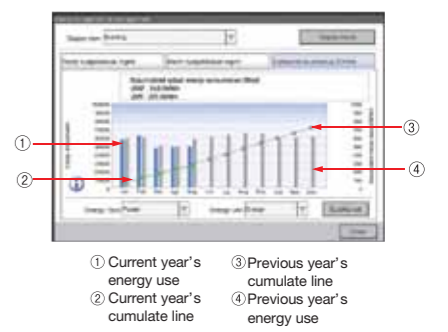

Information concerning energy management of the system can be viewed on the user's own PC via LAN.



Energy consumption is automatically evaluated for each room.

Based on the accumulated data, the *intelligent touch Manager* automatically identifies rooms and air conditioning units that substantially deviate from operation rules established by the user for operation time and predetermined temperature settings. A benchmark showing ways to further reduce energy consumption can be displayed to alert users to even greater energy and cost savings.

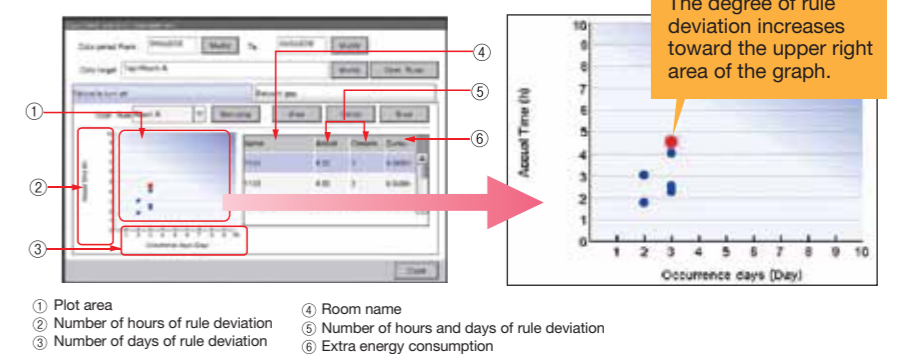

## Reporting the power consumption of VRF system for each tenant

**With the PPD function, power consumption can be calculated for each indoor unit (Option)**

The energy consumption is proportionally calculated for each indoor unit. The data can be used for energy management and calculation of air conditioning usage fees for respective tenants.

Operational information of individual indoor units are monitored, based on distribution of power consumption of outdoor units.

Daikin's PPD keeps track of power distribution for each indoor unit. It performs air conditioning billing calculations quickly and automatically.

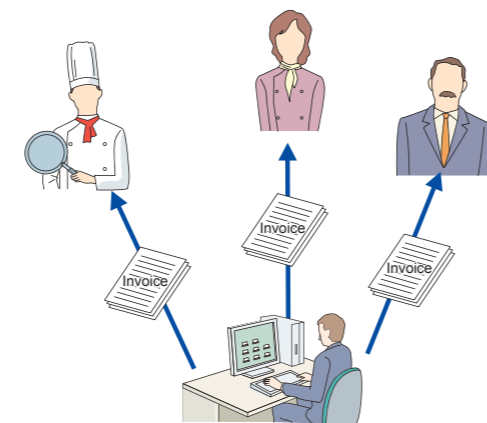
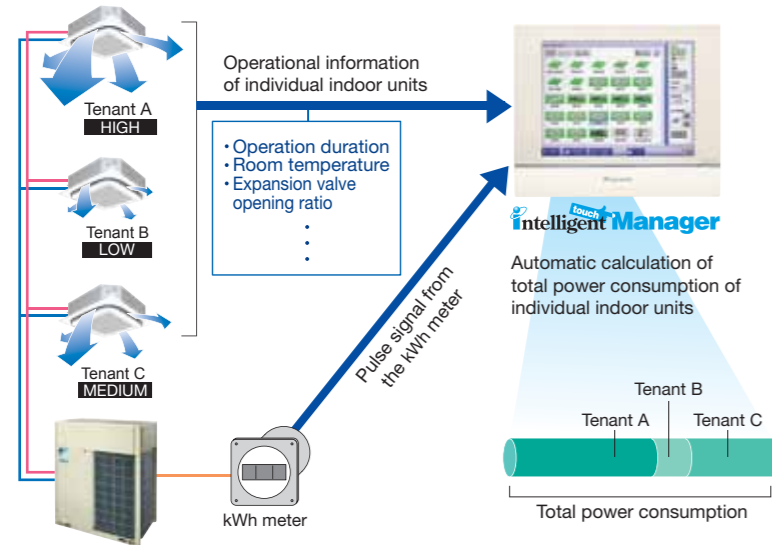

\* PPD (Power Proportional Distribution) is Daikin's proprietary calculation method.

### It is easy to output PPD data.

PPD data is output in CSV format to a PC or USB memory device and can be freely processed and managed.

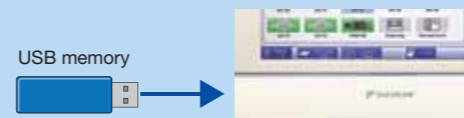

## Air Conditioning Network Service System

### Preventive Maintenance

The *intelligent touch Manager* can be connected to Daikin's own Air Conditioning Network Service System for remote monitoring and verification of operation status for VRF system. By its ability to predict malfunctions, this service provides customers with additional peace of mind.

### Enhanced convenience with link to the Air Conditioning Network Service System

The *intelligent touch Manager* connects seamlessly to Daikin's 24-hour Air Conditioning Network Service System.

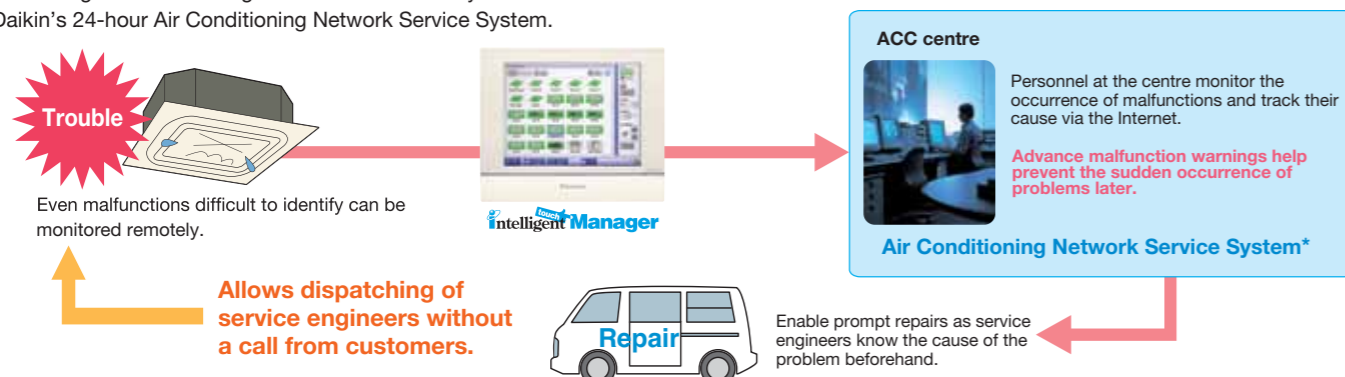

\*Because of restrictions in applicable areas and release times, please consult a Daikin representative separately for details.

## Comfort with minimum energy

In office buildings, approx.50% of total electricity consumption is occupied by air conditioning. *intelligent touch Manager* provides a huge potential of cost saving for office application with its functions such as schedule programme and setpoint restriction.



### Typical energy consumption of an office building

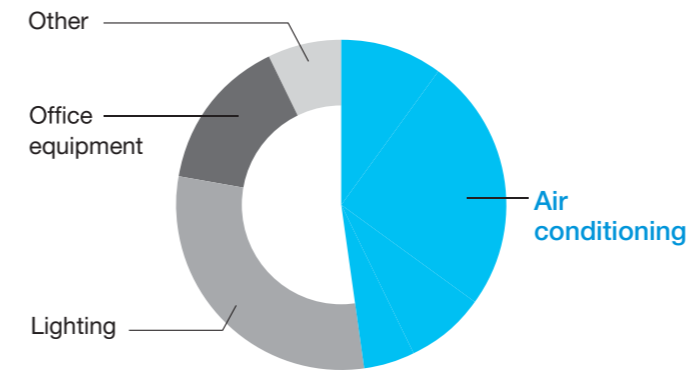

### Case study: Energy Saving by control system

The following is an actual case of energy saving done by our control system. By investigating VRF usage in each area of the building to clarify the deviation of power consumption and to find out the potential of energy saving, the new control programme succeeded in reducing 16.5% of the power consumption. Preventing VRF operation in unoccupied period and excessive setpoint in unnecessary area mainly contributed to the reduction. As the new programme restricted only unnecessary part of VRF usage, the power consumption decreased without losing comfort of users.

#### Control programme

Function		Before	After
Schedule programme		No	Yes
Setpoint restriction with Schedule function	Office	No	Yes ( 22 - 25degC )
	Common area	No	Yes ( 24 - 26degC )

### Average of daily Power Consumption based on actual measured data

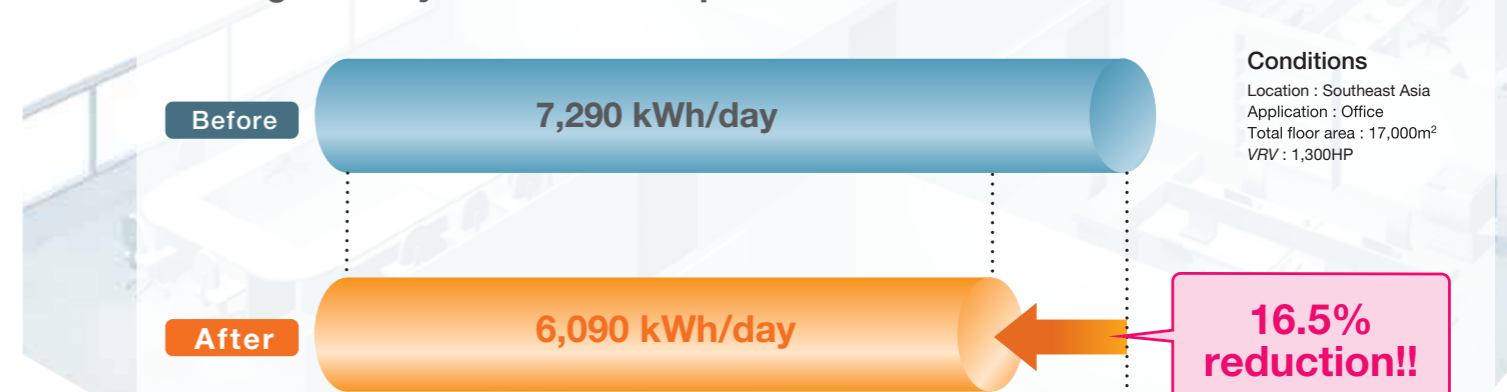

## Automatic control based on occupancy and check-in/-out status of each room

### Hospitality with economy

A hotel's reputation depends on how welcomed and comfortable guests feel during their stay. Yet at the same time, hotel owners might want to focus on cost saving.

*intelligent touch Manager* provides optimum control for hotel application to manage comfortable & energy saving air conditioning system.

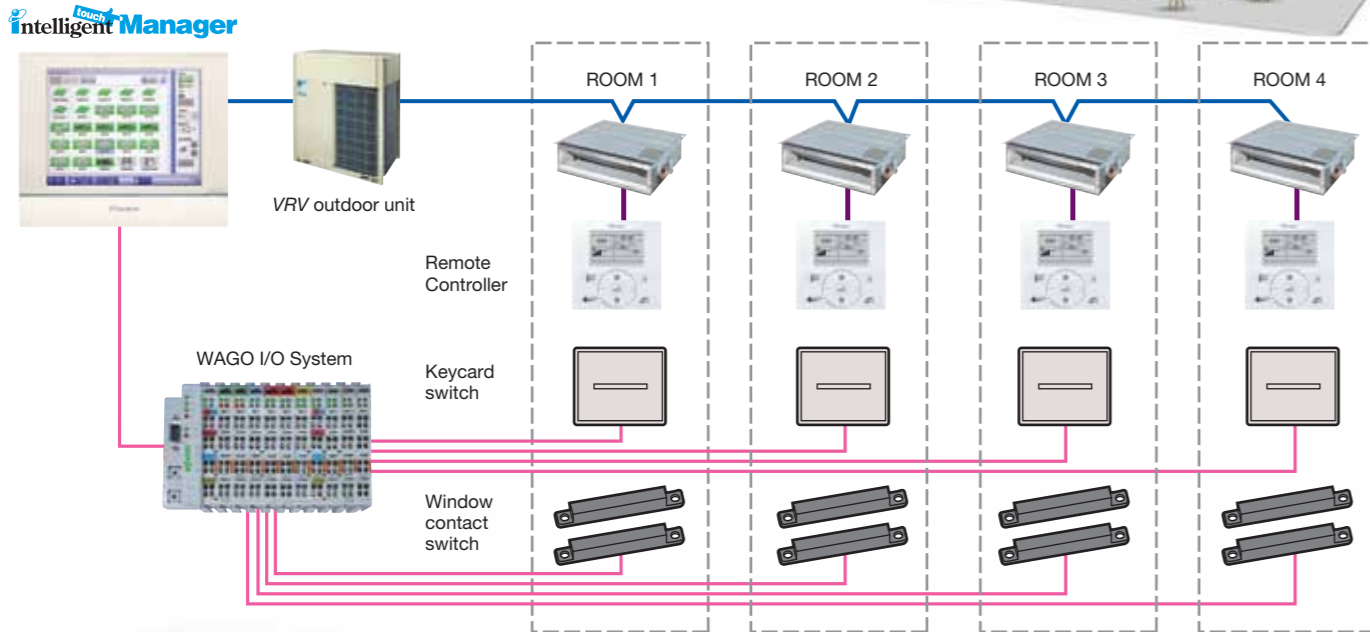

### Interlock control

Interlocking with Keycard switches and Window contact switches, iTM automatically changes VRV operation status according to each room condition.

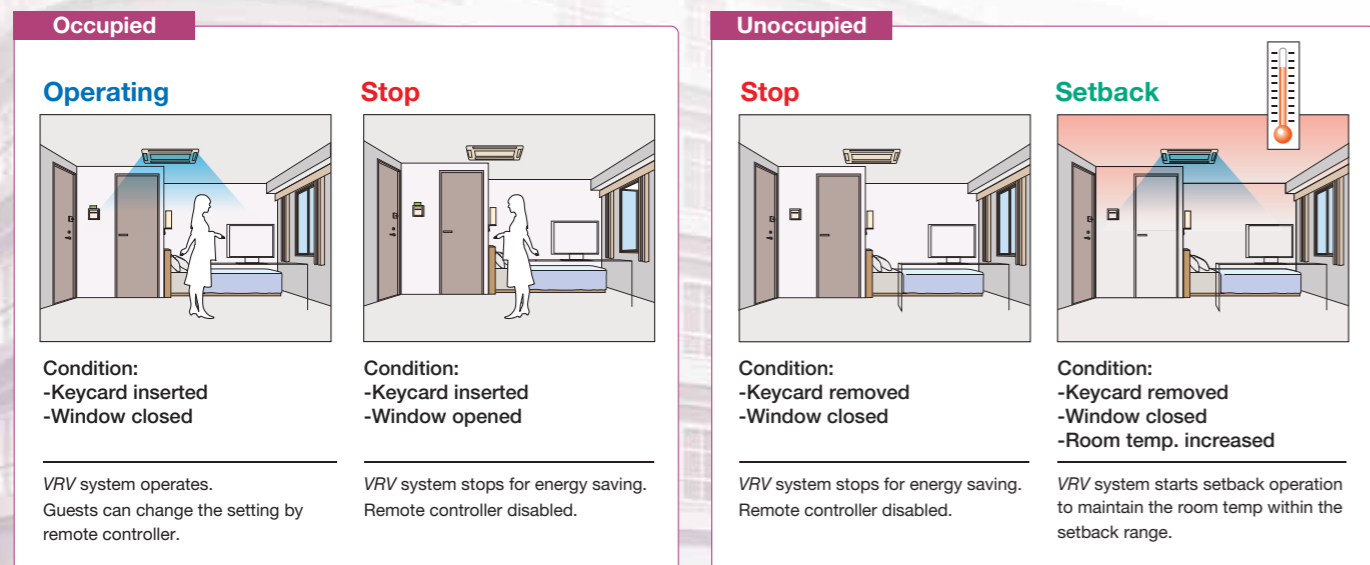

## Stable operation in server room to protect valuable data



### Rotation system

Two or more air conditioning units operate alternately to equalize and extend the product life cycle of VRV system.

*intelligent touch Manager* changes the combination of operating units and a backup unit by turns. The combination moves from the pattern 1 to 2, 2 to 3, 3 to 1 by schedule programme.

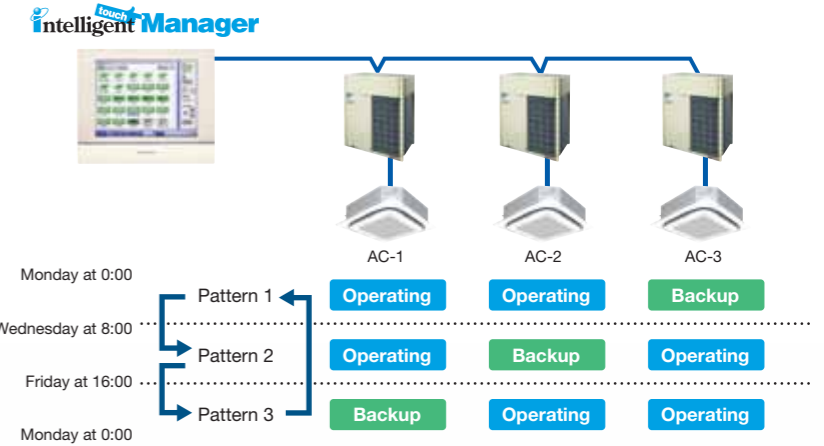

### Backup operation in case of a malfunction

Backup unit automatically starts instead of a malfunctioned unit.

When a malfunction occurs, *intelligent touch Manager* detects it and send an e-mail to a facility manager. Also *intelligent touch Manager* starts a backup unit by interlock programme to keep two indoor units operating.

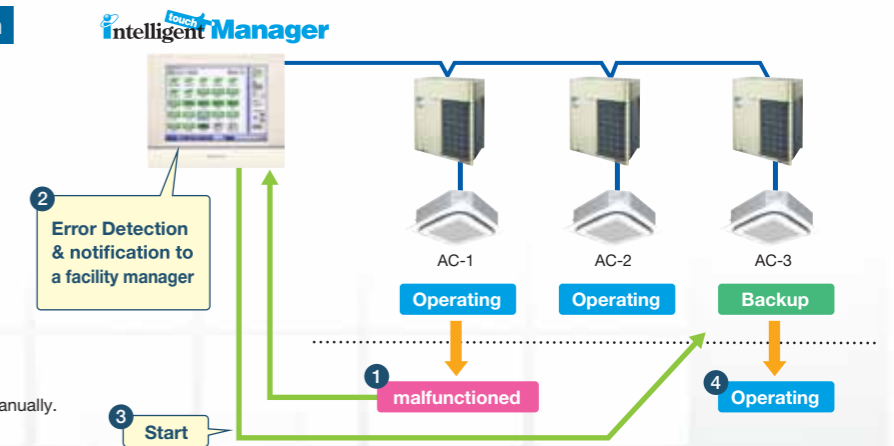

### Additional start up at high temperature

If an abnormal increase in room temperature is detected, a backup unit automatically starts.

When temperature in a server room becomes higher than pre-determined temperature, *intelligent touch Manager* starts a backup unit by interlock program to maintain room temperature. At the same time, *intelligent touch Manager* sends an e-mail to a facility manager to notify the temperature increase. To detect the temperature, sensors of indoor units or remote controllers are available. (No additional equipment is necessary.)

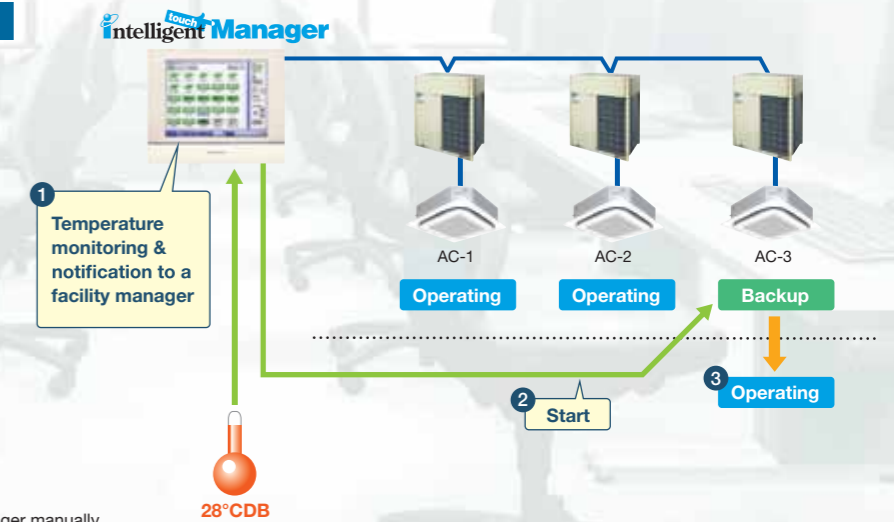

## intelligent touch Manager function

Category	Function	Remarks	
Basic functions	<i>iTM plus adaptor</i> (DCM601A52)	Maximum number of adaptors: 7	
	Management points	Maximum number of management points: 650 (Number of DIII connection management points: 512)	
	Areas	Maximum number of areas: 650 Maximum area hierarchies: 10	
	Supported languages	English, French, German, Italian, Spanish, Portuguese, Dutch, Chinese, and Japanese	
	Monitoring screens	Icon view	Icons show the operation status of equipment.
		List view	Detailed information of each management point is displayed.
		Layout view	Up to 60 screens can be created. (Engineering option)
History	Up to 500,000 events are recorded in history including malfunctions, operations, automatic control, and system information. Operation origin is also recorded.		
Automatic control	Schedule	Number of programmes:100 Up to 20 actions/day can be set.	
		Weekly schedule	7 days of the week + 5 special days can be set.
		Yearly calendar	Special days can be specified by date or month/week/day of the week. Special day settings can be reused every year.
		Seasonal schedule	Programmes for respective seasons can be switched by date.
	Interlock	Number of programmes:500 Interlock is possible for on/off, malfunction, analogue value, and operation mode switching.	
	Emergency stop	Number of programmes:31	
	Automatic changeover	Number of changeover groups:512	
	Temperature limit	Number of temperature limit groups: 8 Upper limit range: 32-50°C Lower limit range: 2-16°C	
	Sliding temperature	Number of sliding temperature groups: 8 Outdoor temperature range: 18-34°C Setpoint range: 16-32°C	
	Heating Mode Optimisation (HMO)	Unneeded heating is prevented.	
Timer extension	Operation stop is selectable from 30, 60, 90, 120, 150, and 180 minutes.		
Setback	Setback setpoint can be set for 2 patterns. Temperature range: 1-7°C , -1--7°C (setpoint shift amount)		
Data control	Power Proportional Distribution	Hourly Power Proportional Distribution results up to 13 months are recorded. The system supports data output in CSV format.	
	Energy Navigator	Actual results of daily/monthly energy consumption are shown in graphs. Comparisons can be made with predetermined values/actual results of the previous year. Inefficient operation of VRF indoor units is automatically identified, and energy waste is calculated.	
Remote access	Web access	Web browsers can display the same type of screen as the <i>intelligent touch Manager</i> . Up to 4 administrators and 60 general users can be registered. Screens and operation accessible to general users can be restricted.	
	E-mail alerts	Up to 10 e-mail addresses can be set. Addresses for sending malfunction alerts can be set by range of management points. The SMTP server authentication method is selectable from no authentication, POP before SMTP, and SMTP-AUTH.	
System	Automatic registration	Indoor units connected to DIII-NET are automatically detected, and icons for respective models are automatically registered.	
	Security	Screen lock functions are available. Access restrictions can be set for each general user.	
	Screen savers	Screen savers are selectable from 3 patterns.	
	Setting of contact information	Contact information for servicing can be registered.	
Air Conditioning Network Service	Air Conditioning Network Service System	A service agreement needs to be concluded.	
	Energy Saving Air Conditioning Network Service System	A service agreement needs to be concluded.	

## Types of management points and target equipment/interface

Management point	Supported equipment	Number of management points
Indoor	DIII-compatible indoor units	Maximum: 512 *1
	AHU kit (EKEQFCB,EKEQDCB,EKEQMCB)	
	Interface adaptor for SkyAir (DTA102A52 , DTA112BA51)	
	Interface adaptor for residential indoor unit (KRP928BB2S)	
Outdoor	VRV outdoor units	Maximum: 80
	Ventilator	Maximum: 512 *1
D3 Chiller	DIII-compatible air-cooled chillers (UWA/Y) / water-cooled chillers (ZUW)	Maximum: 320 *2
Di	Di port of <i>intelligent touch Manager</i>	Maximum: 32 *3
	Di port of <i>iTM plus adaptor</i>	
D3 Di	DIIIDi Unit (DEC101A51)	Maximum: 512 *1
External Di	WAGO Di	Maximum: 512 *4
D3 Dio	DIIIDio Unit (DEC102A51)	Maximum: 512 *1
	General-purpose adaptor (DTA103A51)	
External Dio	WAGO Di, Do	Maximum: 512 *4
Pi	Pi port of <i>intelligent touch Manager</i>	Maximum: 32 *3
	Pi port of <i>iTM plus adaptor</i>	
Internal Pi	Energy consumption of VRV outdoor units	Maximum: 80
External Pi	WAGO Pi (Not available for PPD function)	Maximum: 512 *4
External Ao	WAGO Ao	
External Ai	WAGO Ai	
Internal Ai	Room temperature, setpoint of indoor units D3 Chiller outlet/inlet water temperatures	Maximum: 512 *4
BACnet Di	BACnet object BI/BO/BV can be linked	Maximum: 512 *5
BACnet Dio	BACnet object BI/BO/BV can be linked	
BACnet Ai	BACnet object AI/AO/AV can be linked	
BACnet Ao	BACnet oboject AO/AV can be linked	
AHU *6	BACnet connectable AHU using MicroTech III	Maximum: 20

\*1: Total of DIII connection equipment (Indoor, Ventilator, D3 Chiller, D3 Di, D3 Dio) \*2: Maximum number of management points for D3 Chiller only  
\*3: Total of Di/Pi management points \*4: Total of External Di, External Dio, External Ai, External Ao, External Pi and Internal Ai \*5: Total of BACnet points (include AHU\*6) \*6: AHU count as 20 BACnet points

## DAIKIN supplied equipment & Software option

Model	Item	
DCM601A51	<i>intelligent touch Manager</i>	
DCM601A52	<i>iTM plus adaptor</i> (Option)	
DCM002A51	iTM power proportional distribution software (Option)	
DCM008A51	iTM energy navigator software (Option)	
DCM009A51	BACnet client software (Option)	
WAGO I/O system	Di module (DC24V/4.5mA) : 750-400,750-432	Thermistor module (NTC20K) : 750-461/020-000
	Di module (DC24V/2.8mA) : 750-430	Thermistor module (Pt 100/RTD) : 750-461/750-460
	Do module (AC230V/DC30V 2A) : 750-513/000-001	Thermistor module (Pt 1000/RTD) : 750-461/000-003,750-460/000-003
	Do module (DC24V 0.5A) : 750-504	Thermistor module (Ni 100/RTD) : 750-461/000-004
	Ai module (4~20mA 12bit) : 750-454,750-455	Thermistor module (Ni 1000 TK6180/RTD) : 750-461/000-005,750-460/000-005
	Ai module (-10~10V 13bit) : 750-479	Pi module : 750-638
	Ai module (0~10V 12bit) : 750-459	
Ao module (4~20mA 12bit) : 750-554,750-555		
Ao module (0~10V 10bit) : 750-560		
Ao module (0~10V 12bit) : 750-559		

## Locally supplied equipment

Item	Specification
USB memory	USB 2.0 Up to 32GB memory can use
PC for Web access	Web browser : Internet Explorer 11 Firefox 26.0 Chrome 32.0 Flash Player Ver11.9.900.170

## intelligent touch Manager

Port	Number	Use
D III	1ch	DIII-NET (Up to 64 groups)
LAN	1ch	Web Access (100BASE-TX)
RS485	1ch	External I/O module (Di,Dio,Ai,Ao,Pi)
Di(Pi)	4ch	Emergency stop input (Di1) Pulse input,contact signal input
plus ADP IF	1ch	iTM plus adaptor (Up to 7 adaptors)
internal modem (option)	1ch	Air Conditioning Network Service System

POWER SUPPLY : DCM601A51 AC100-240V(±10%)(50/60Hz)  
 INPUT : 23W  
 MASS : 2.4kg  
 FUSE AMP : 3.15A  
 Operating temperature limit : -0°C - +40°C  
 Operating humidity limit : MAX.15 - 85 %  
 Storage temperature range : -15°C - +60°C  
 Installation direction : Vertical direction only

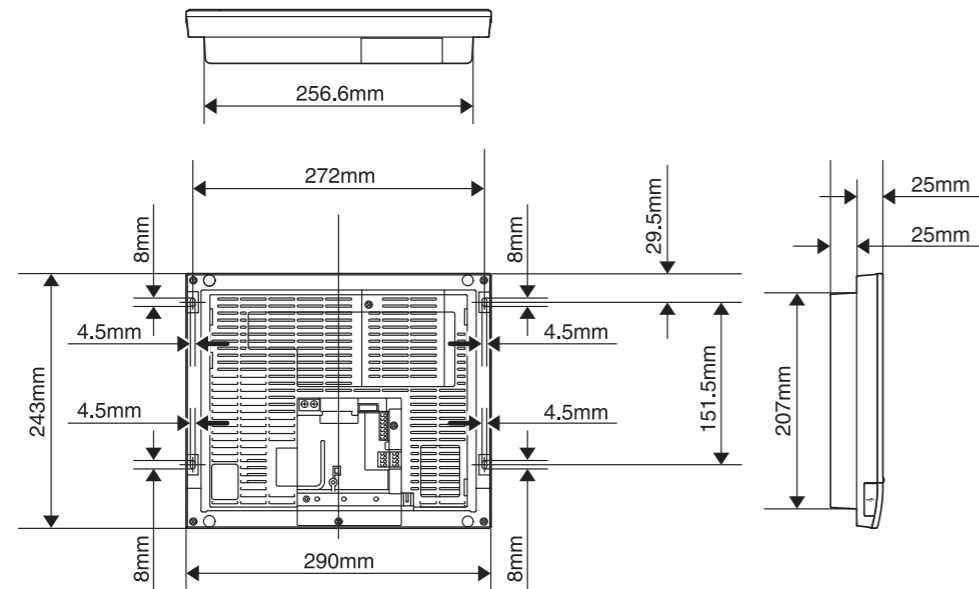

## iTM plus adaptor (DCM601A52) Input/Output port

Port	Number	Use
plus ADP IF	1ch	iTM plus adaptor (Up to 7 adaptors)
D III	1ch	DIII-NET (Up to 64 groups)
Di(Pi)	4ch	Pulse input,contact signal input

POWER SUPPLY : DCM601A52 AC100V-240V(±10%)(50/60Hz)  
 INPUT : 6W  
 MASS : 0.5kg  
 FUSE AMP : 3.15A  
 Operating temperature limit : -10°C - +50°C  
 Operating humidity limit : MAX.15 - 85%  
 Storage temperature range : -15°C - +60°C  
 Installation direction : Vertical direction only

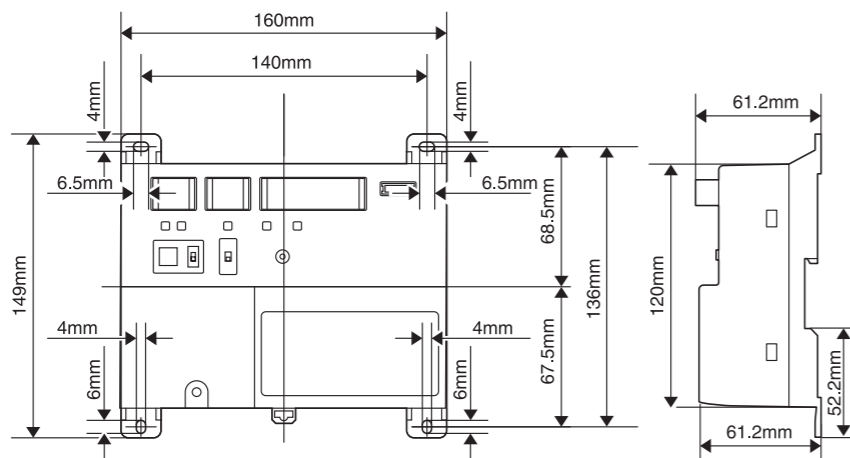

# Daikin offers a variety of control systems

## Convenient controllers that offer more freedom to administrators



DCS601C51

**Intelligent touch Controller**

### Ease of use and expanded control functions

The user-friendly controller features colours, multilingual function, and icons in the display for ease of understanding. A wide variety of control methods can be accommodated, permitting administrators to monitor and operate the system even when they are away from the controller.

## Connect VRV to your BMS via BACnet® or LONWORKS®



Compatible with BACnet® and LONWORKS®, the two leading open network communication protocols, Daikin offers interfaces that provide a seamless connection between VRV and your BMS.

**Dedicated interfaces make Daikin air conditioners freely compatible with open networks**

### BACnet®

Seamless connection between VRV and BACnet® open network protocol.



DMS502B51 (Interface for use in BACnet®)

### LONWORKS®

Facilitating the network integration of VRV and LONWORKS®



DMS504B51 (Interface for use in LONWORKS®)

Notes:  
 1. BACnet® is a registered trademark of American Society of Heating, Refrigerating and Air-Conditioning Engineers (ASHRAE).  
 2. LONWORKS® is a trademark of Echelon Corporation registered in the United States and other countries.